

Question block created by wizard

This exam contains 92 questions.

1. "When a body is acted upon by an external force, the rate of change of momentum is proportional to the force and takes place in the direction of the force."

Which law is this?

- (a) Newtons third law.
- (b) Newtons first law
- (c) Newtons second law.

If choice c is selected set score to 1.

2. A turbo prop engine gives...

- (a) a small acceleration to a large mass of air.
- (b) a large acceleration to a small mass of air.
- (c) a large acceleration to a large weight of air.

If choice a is selected set score to 1.

3. The difference in operation between a propeller and a jet engine can be summarized as follows:

- (a) A propeller accelerates a large quantity of air rearwards at a low rate. A jet engine accelerates a small quantity of air rearwards at a high rate.
- (b) Propeller is pulling while a jet engine is only compressing air.
- (c) A propeller accelerates a large quantity of air rearwards at a high rate. A jet engine accelerates a small quantity of air rearwards at a low rate.

If choice a is selected set score to 1.

4. Why are dual and triple spool axial compressors developed?

- (a) Reduces weight.
- (b) Operational flexibility.
- (c) Only due to their high altitude operation features.

If choice b is selected set score to 1.

5. The basic equation for thrust is...

- (a) thrust = mass · acceleration.
- (b) thrust = force · acceleration.

- o (c) thrust = mass · velocity.

If choice a is selected set score to 1.

- 6.** The conditions affecting the weight of a given volume of air are: pressure, temperature and humidity, therefore:
- (a) Density decreases as temperature increases.
 - o (b) Density decreases as temperature decreases.
 - o (c) Density increases as temperature increases.

If choice a is selected set score to 1.

- 7.** The bypass ratio of a modern turbofan is....

- o (a) around 2 : 1.
- o (b) around 5 : 1.
- (c) around 8 : 1.

If choice c is selected set score to 1.

- 8.** The Engine Pressure Ratio is affected by...

- o (a) turbine inlet temperature.
- o (b) turbine outlet speed, low pressure shaft.
- (c) compressor inlet temperature.

If choice c is selected set score to 1.

- 9.** What happens to the thrust if temperature increases?

The thrust...

- o (a) increases.
- o (b) does not change except during extremely low temperature (-40 degrees Celsius).
- (c) decreases.

If choice c is selected set score to 1.

- 10.** When an aircraft is in flight, what accompanies the increase of air speed?

- o (a) temperature.
- o (b) altitude.
- (c) ram effect.

If choice c is selected set score to 1.

11. How is the effectiveness expressed for an engine intake?

- (a) Mass airflow.
- (b) Pressure recovery.
- (c) Engine power.

If choice b is selected set score to 1.

12. What is the most effective intake shape for supersonic speeds?

- (a) Divergent - convergent duct.
- (b) Straight duct.
- (c) Convergent - divergent duct.

If choice c is selected set score to 1.

13. What are the advantages of the intake as indicated below?



- (a) Allow high air speeds
- (b) Prevent foreign object damage
- (c) Allow high maneuverability

If choice c is selected set score to 1.

14. How is the hot air anti-ice system activated?

- (a) Manually from the flightdeck

- o (b) The system is always on and can not be switched off
- o (c) Automatically when ice is detected

If choice a is selected set score to 1.

15. On large commercial aircraft with podded engines, what is the normal way to protect the engine from ice?

- o (a) Using electrical heating
- o (b) Using air from the engine to inflate rubber boots
- (c) Using hot air from the engines

If choice c is selected set score to 1.

16. What is the disadvantage of a centrifugal compressor?

- (a) Large frontal areas for a given mass flow.
- o (b) Weight.
- o (c) Low overall compression ratio.

If choice a is selected set score to 1.

17. Which drawing shows the dove tail fixing type?



- (a)

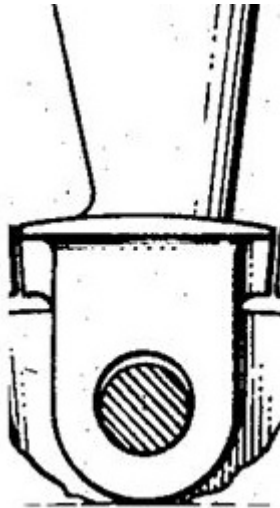

(b)

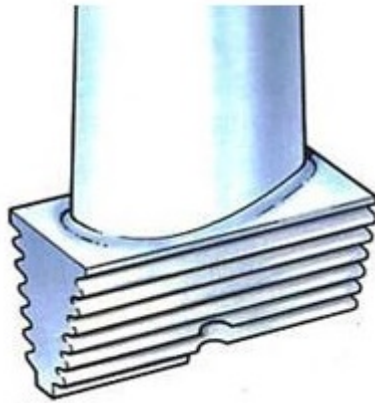

(c)

If choice a is selected set score to 1.

18. Fan blades are normally...

- (a) replaceable in moment weighted pairs.
- (b) not replaced on installed engine.
- (c) cleaned after each flight to maintain efficiency.

If choice a is selected set score to 1.

19. The relative angle of attack of the compressor blade is a result of...

- (a) inlet air velocity and compressor temperature.
- (b) compressor rpm and temperature.
- (c) inlet air velocity and compressor rpm.

If choice c is selected set score to 1.

20. A compressor stall is best explained as...

- (a) air stops flowing smoothly rearwards on engine shutdown.
- (b) trust reverser.
- (c) the smooth rearwards flow of air comes to a stop.

If choice c is selected set score to 1.

21. The purpose of the variable inlet guide vanes is to direct the incoming air into the...

- (a) combustion chamber at the correct angle so as to achieve the optimum angle of attack.
- (b) turbine at the correct angle so as to achieve the optimum angle of flow to the first stage.
- (c) compressor at the correct angle so as to achieve the optimum angle of attack of the first stage rotor blades.

If choice c is selected set score to 1.

22. One of the primary limiting factors on pressure ratio in modern designs is that the:

- (a) location that the temperature is taken.
- (b) air heats up as it is compressed.
- (c) air cools down as it is compressed.

If choice b is selected set score to 1.

23. The combustion system consists of...

- (a) perforated flame tubes, outer air casing(s), a burner system and igniter plugs.
- (b) perforated cooling pipes and fuel injectors.
- (c) fuel injector and spark plug.

If choice a is selected set score to 1.

24. The primary air through the combustion chamber is divided in....

- (a) 75% for burning mixture and 25% for cooling.
- (b) 80% for cooling and 20% for mixture burning.
- (c) 25% for burning mixture and 75% for cooling.

If choice c is selected set score to 1.

25. In what zone of the combustion section is the highest temperature?

- (a) Dilution zone.

- (b) Primary zone.

- o (c) Intermediate zone.

If choice b is selected set score to 1.

26. What is the reason to use stagger angle on turbine blades in a gas turbine engine?

- o (a) It results in a lower gas pressure and higher velocity at the tip.
- o (b) Simply cooling at high power settings.
- (c) It results in a higher gas pressure and lower velocity at the blade root.

If choice c is selected set score to 1.

27. Are nozzle guide vanes hollow? If yes, why?

- (a) Yes, to allow cooling air to pass through them
- o (b) Yes, to make them lighter and stronger
- o (c) No

If choice a is selected set score to 1.

28. Which phase of turbine blade creep marks the end of its useful life?

- o (a) Primary.
- o (b) Secondary.
- (c) Tertiary.

If choice c is selected set score to 1.

29. The first stator vane assy downstream of the combustion chamber is the

- o (a) variable stator vane.
- o (b) turbine disk.
- (c) nozzle guide vane.

If choice c is selected set score to 1.

30. What is the function of the inner exhaust cone at the rear face of the turbine disc?

The cone....

- o (a) decreases the exhaust area to the rear and maximizes the gas velocity.
- o (b) decreases the exhaust area to the rear and lowers the gas velocity.
- (c) increases the exhaust area to the rear and lowers the gas velocity.

If choice c is selected set score to 1.

31. On commercial gas turbine engines the exhaust duct is....

- (a) divergent.
- (b) convergent / divergent.
- (c) convergent.

If choice c is selected set score to 1.

32. What type of thrust reverser is shown in the picture?

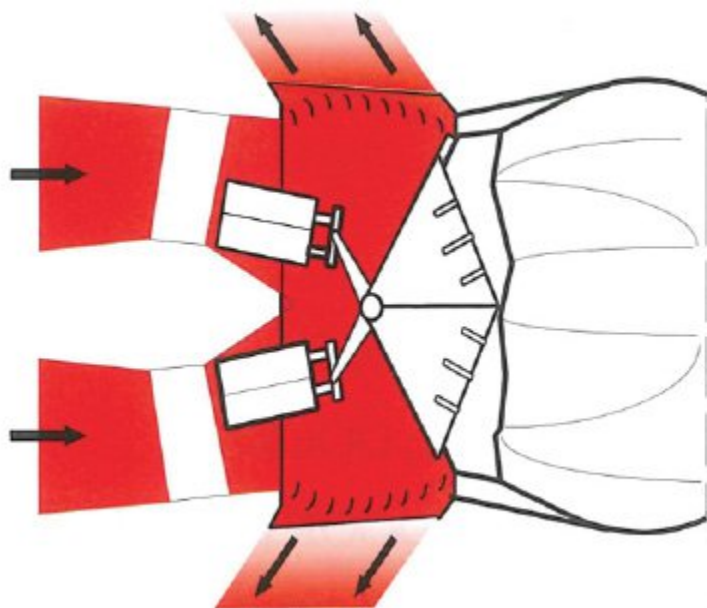

- (a) Bucket door reverser.
- (b) Cold stream reverser.
- (c) Clamshell door reverser.

If choice c is selected set score to 1.

33. Labyrinth Seals are supported with engine...

- (a) springs.
- (b) oil pressure.
- (c) air pressure.

If choice c is selected set score to 1.

34. Why do bearing assemblies often contain a cage?

- (a) To keep the rollers or balls in place.

- (b) To transmit forces to the raceway.
- (c) To make sure lubrication is 100%.

If choice a is selected set score to 1.

35. Engine bearing cavities are sealed with labyrinth seals and are supported....

- (a) with engine air pressure.
- (b) in a powder substance to insure longer life support.
- (c) with engine oil pressure

If choice a is selected set score to 1.

36. At extreme cold starting conditions the prime limiting factor for fuel is:

- (a) Smoke point.
- (b) Viscosity.
- (c) Flashpoint.

If choice b is selected set score to 1.

37. Tracer A is an additive to detect leaks....

- (a) in airport fuel systems.
- (b) in aircraft systems.
- (c) in engines.

If choice a is selected set score to 1.

38. Static dissipator additive is used to....

- (a) prevent static charging of fuel systems.
- (b) prevent corrosion of metal fuel system components.
- (c) to maintain stability of jet fuel during storage.

If choice a is selected set score to 1.

39. Increasing the flashpoint will make fuel safer but....

- (a) a hot start will become more difficult.
- (b) a cold start will become more difficult.
- (c) the fuel consumption will increase drastically.

If choice b is selected set score to 1.

40. Why is it required to wait five minutes after engine shut down before removing the oil filter cap?

- (a) It allows the tank pressure to bleed off.
- o (b) So that all the oil loses its air through the breather and foaming of oil is reduced.
- o (c) That all oil can drain back to the gearbox.

If choice a is selected set score to 1.

41. When the electronic engine control has to be replaced, what happens with the programming plug?

The programming plug must...

- (a) remain with the engine.
- o (b) be reprogrammed for the new electronic engine control.
- o (c) be renewed.

If choice a is selected set score to 1.

42. What is the purpose of an engine oil system?

- o (a) Bearing lubrication and heating fuel.
- (b) Bearing cooling, lubrication and heating fuel.
- o (c) Bearing cooling, lubrication and cooling fuel.

If choice b is selected set score to 1.

43. A cleanable filter is made of...

- (a) woven wire.
- o (b) plastic mesh.
- o (c) paper mesh.

If choice a is selected set score to 1.

44. The fuel control is an engine driven accessory. It can operate by mechanical, hydraulic, electrical, or pneumatic forces in various combinations.

What is the purpose of the fuel control?

- o (a) Control the fuel flow from the aircraft fuel booster pumps.
- (b) Maintain a correct combustion air-to fuel mixture.

- o (c) Limit the amount of fuel to the combustion chamber.

If choice b is selected set score to 1.

45. When on the EICAS the fuel bypass message is indicated, where does the signal come from?

- o (a) Low pressure fuel pump bypass valve.
- o (b) Main pressure fuel pump bypass valve.
- (c) Differential pressure switch.

If choice c is selected set score to 1.

46. The fuel flow transmitter (FFT) uses electromagnetic pulses...

- o (a) to control the amount of fuel sent to the fuel control unit.
- (b) to measure the rate of fuel flow.
- o (c) generated by the fuel booster pumps.

If choice b is selected set score to 1.

47. What is the purpose of the L.P. pump?

To ensure...

- o (a) rapid acceleration when the throttle is opened.
- o (b) that the fuel nozzles get the correct fuel pressure.
- (c) that enough fuel flow is delivered to the high pressure pump.

If choice c is selected set score to 1.

48. What is the function of linear variable differential transformers (LVDT)?

- o (a) Control signals.
- o (b) Warning signals.
- (c) Feedback signals.

If choice c is selected set score to 1.

49. Thrust lever position is transmitted to the EEC via a thrust lever resolver, as Thrust Lever....

- o (a) cables.
- o (b) solenoid energized in a series.
- (c) angle.

If choice c is selected set score to 1.

50. What is the function of the accessory cooling system?

- (a) Cool the engine components and air intake.
- (b) To remove excess heat and ventilation of the components.
- (c) Ventilate the engine bleed air, to the atmosphere.

If choice b is selected set score to 1.

51. What air is supplied to the nacelle zone?

- (a) High pressure compressor air.
- (b) Fan air.
- (c) Low pressure turbine air.

If choice b is selected set score to 1.

52. The fail safe position of the compressor control bleed valve in case of loss of fuel pressure or electrical control is....

- (a) intermediate.
- (b) closed.
- (c) open.

If choice c is selected set score to 1.

53. The exact sequence of the starting procedure is important since there must be...

- (a) sufficient air flow through the engine to support combustion.
- (b) indication before you can get fuel flow to the engine.
- (c) oil pressure before rotation of the engine high speed compressor.

If choice a is selected set score to 1.

54. If the starter were cut off below the self-accelerating speed, the engine could?

- (a) This is not a problem because the starter would re-engage to continue the starting process.
- (b) Catch fire externally.
- (c) Fail to accelerate to idle speed.

If choice c is selected set score to 1.

55. The ignition power supply includes two independent ignition exciters installed on the engine.

Each ignition exciter is...

- (a) converting 115-volt ac to 24-kilovolts ac (nominal).
- (b) of the capacitive-discharge type, converting 115-volt ac to 24-kilovolts dc (nominal).
- (c) an independent battery device, storing its own power.

If choice b is selected set score to 1.

56. When will continuous ignition be selected?

- (a) For flight in bad weather conditions.
- (b) Only for start-up.
- (c) After take-off.

If choice a is selected set score to 1.

57. Why is it required to ground the cable terminal of an ignition system after detaching the cable from the igniter plug?

- (a) To dissipate the energy stored in the system
- (b) To prevent an open in the ignition cable
- (c) To prevent a short in the cable.

If choice a is selected set score to 1.

58. Why is the EGT indication very important?

- (a) It gives a direct relationship to engine power.
- (b) It is the only engine condition monitoring parameter.
- (c) It gives information about the heaviest loaded part, the turbine.

If choice c is selected set score to 1.

59. What does engine pressure ratio on a modern turbofan engine indicate?

- (a) The air pressure at the exhaust.
- (b) The pressure ratio across the fan.
- (c) The air pressure produced by the compressor.

If choice b is selected set score to 1.

- 60.** The oil pressure transmitter senses the difference between pressure pump delivery pressure and...

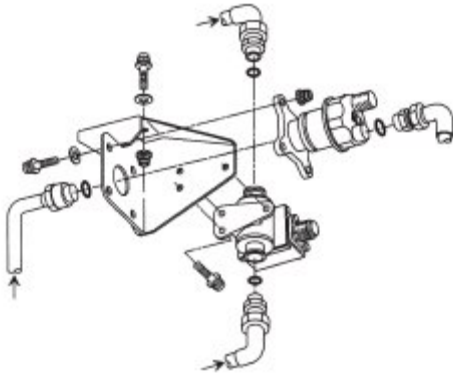

- (a) the ISA parameters.
- (b) the gear box pressure.
- (c) the FCOC (Fuel Cooled Oil Cooler).

If choice b is selected set score to 1.

- 61.** The sensors are induction-type tachometers. The tip on each sensor has a permanent magnet with three coil assemblies.

This best describes?

- (a) AVM (airborn vibration system).
- (b) Fuel pump pressure indication system.
- (c) Engine tachometer system.

If choice c is selected set score to 1.

- 62.** Which indication component is using a permanent magnet with three coil assemblies?

- (a) The engine tachometer system.
- (b) The fuel pump pressure indication system.
- (c) The airborne vibration system signal conditioner pick up points.

If choice a is selected set score to 1.

- 63.** Adverse conditions, as far as the engine is concerned, is operation in high ambient temperature and/or high altitude. These are adverse conditions.

Which two systems are available to overcome these conditions?

- (a) Remove the throttle stops for more thrust.

- (b) Water injection and water / methanol injection
- o (c) Turbine case cooling and bleed air control.

If choice b is selected set score to 1.

64. Injection of water into the engine inlet will cool the inlet air and hence its density will...

- o (a) get thinner.
- (b) increase.
- o (c) decrease.

If choice b is selected set score to 1.

65. The increased thrust is obtained by injecting and burning large quantities of fuel in the specially shaped engine exhaust system. This is referred to as....

- o (a) hot shot ignition
- o (b) rocket pressure outlet nozzle
- (c) after burner

If choice c is selected set score to 1.

66. What kind of engine is shown in the next picture?

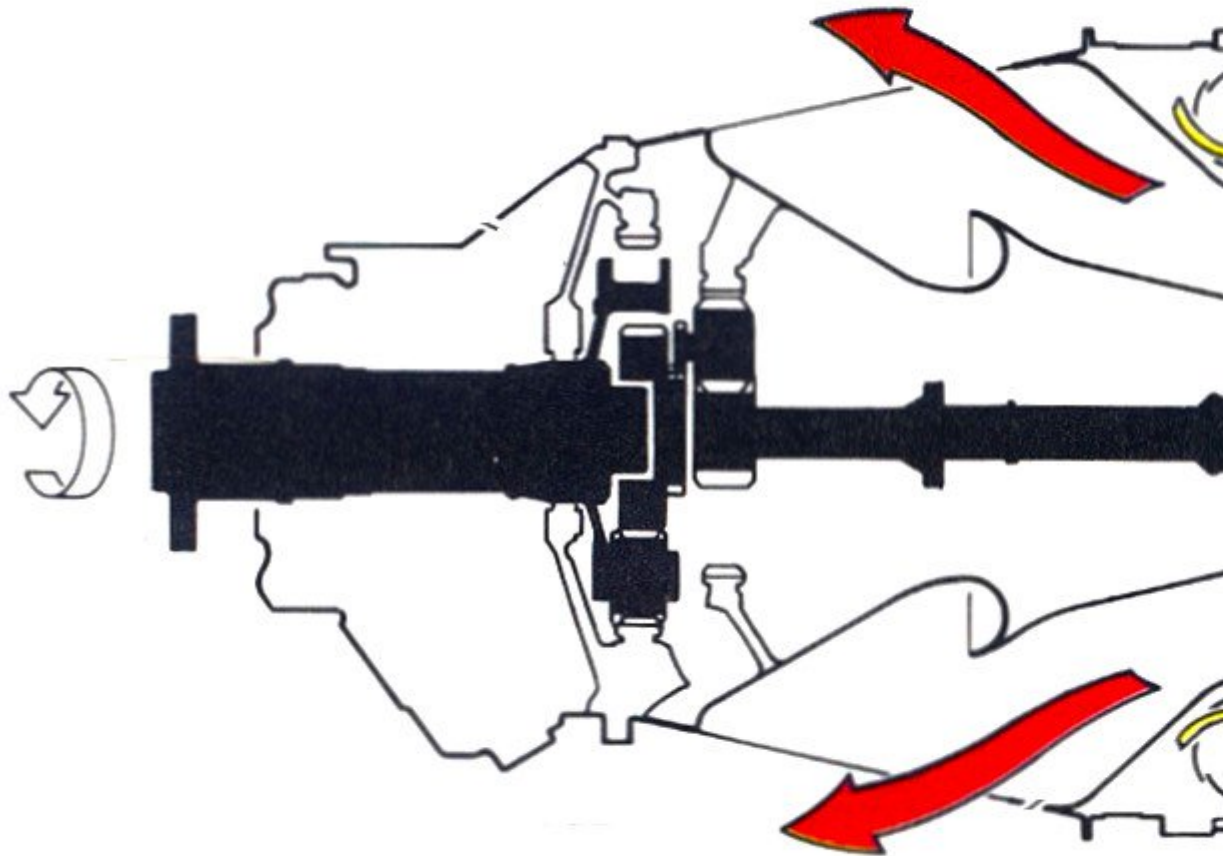

- (a) Triple shaft type.
- (b) Fixed turbine type.
- (c) Free turbine type.

If choice c is selected set score to 1.

67. Which description is the best for: "Epicyclic Planetary Gear Type Reduction Gear"?

- (a) Reduction gear with a rack and pinion.
- (b) Gear is composed of a central input (sun) gear driving two or more spider mounted planet gears.
- (c) Mechanically simple and therefore relatively cheap to manufacture.

If choice b is selected set score to 1.

68. On a typical free turbine turboprop engine the propeller control lever is connected to the...

- (a) propeller governor.
- (b) constant speed fuel mixing unit.
- (c) fuel control unit.

If choice a is selected set score to 1.

69. An turboprop overspeed governor is a backup for the...

- (a) propeller governor.
- (b) radial governor.
- (c) fly weights.

If choice a is selected set score to 1.

70. The most commonly used turbo-shaft engines today are from the...

- (a) single shaft type.
- (b) free-turbine type.
- (c) fixed-turbine type.

If choice b is selected set score to 1.

71. Drive shaft and flexible coupling, turbine helicopters make use of a short shaft system to deliver power to a:

- (a) compressor.
- (b) transmission.
- (c) turbine.

If choice b is selected set score to 1.

72. The parallel spur gear type and the epicyclic type describe...

- (a) excitation gear systems.
- (b) reduction gear systems.
- (c) eccentric gear systems.

If choice b is selected set score to 1.

73. The drive systems are equipped with over running clutches that allow the pilot to perform auto-rotation descent in case of total power loss.

This is true for a...

- (a) turbo-shaft engine on a helicopter.
- (b) reduction gear system from an axial flow bypass engine.
- (c) hydro shaft system.

If choice a is selected set score to 1.

74. The APU gearbox is driven by the...

- (a) power section.
- (b) external source.
- (c) compressor section.

If choice a is selected set score to 1.

75. There are two separate APU protective shutdown systems in the ECU.

They are...

- (a) analog and digital.
- (b) analog and discrete.
- (c) discrete and digital.

If choice a is selected set score to 1.

76. What type of compressor and combustion chamber is used in the power section of an APU?

- (a) Centrifugal compressor with a reverse flow annular combustion chamber.
- (b) Axial flow compressor to save space and annular combustion chamber.
- (c) Axial flow compressor to save space and can combustion chamber.

If choice a is selected set score to 1.

77. The auxilliary power unit or APU is a small gas turbine engine fitted to aircraft.

They can provide...

- (a) electrical power for the inflight entertainment system.
- (b) electric power and pneumatic duct pressure.
- (c) hydraulic pressure.

If choice b is selected set score to 1.

78. When you need no overhead crane or other external hoist devices to change an engine.

This is a...

- (a) Single hoist equipment.
- (b) Bootstrap equipment.
- (c) Chain hoist equipment.

If choice b is selected set score to 1.

79. Powerplants are often divided into zones by fireproof bulkheads.

Bulkheads are usually made of...

- (a) harden steel.
- (b) aluminum alloy.
- (c) stainless steel, titanium.

If choice c is selected set score to 1.

80. What causes the majority of outside noise in a high-bypass engine?

- (a) LP fan.
- (b) Core Engine.
- (c) HP fan.

If choice a is selected set score to 1.

81. The aft engine mount transfers...

- (a) side loads only however it allows for engine growth.
- (b) torsional, vertical and side loads to the pylon.
- (c) thrust loads to the wing

If choice b is selected set score to 1.

82. Turbine case cooling is used to....

- (a) reduce turbine rotor vane clearances and improve engine efficiency.
- o (b) improve gasturbine starting characteristics at high altitude.
- o (c) improve service life of the high pressure compressor.

If choice a is selected set score to 1.

83. The fire extinguishing system protects those sections of the airplane...

- (a) where a fire could initiate. Controls and system status indications are located in the cockpit.
- o (b) selected by each flight crew before departure.
- o (c) where a fire could initiate. Controls and system status indications related to the cabin are located in FWD Cabin Station. All other controls and systems are located in the cockpit.

If choice a is selected set score to 1.

84. Extinguishing agent is discharged through a...

- (a) pipeline system
- o (b) solid state generator the a pipeline system is too heavy for large airplanes.
- o (c) solid material that melts on heat contact.

If choice a is selected set score to 1.

85. This system operates on the rate-of-temperature-rise principle.

What system is this?

- o (a) Thermal switch system
- o (b) Pressure relief system monitoring.
- (c) Thermocouple fire detector system

If choice c is selected set score to 1.

86. Engine areas should be inspected for loose articles and debris before starting the engine.

What areas are they?

- (a) Air intakes and exhaust
- o (b) Only the area directly behind the engine exhaust
- o (c) A distance of 30 meters around the inlet

If choice a is selected set score to 1.

87. What is the most important engine instrument indication to monitor during a start of a turbine engine?

- (a) Engine oil temperature.
- (b) Exhaust gas temperature.
- (c) Oil pressure.

If choice b is selected set score to 1.

88. Routine checks are made to compare the current performance of the engine with its test-cell performance.

Why?

- (a) This trend monitoring is a system of continuous in flight comparison of engine performance parameters with a base line of these same parameters.
- (b) Monitoring is a system of annual requirement to compare engine performance parameters with a base line of these same parameters.
- (c) It is strictly a management tool to ensure personnel are doing their job.

If choice a is selected set score to 1.

89. One procedure that has improved efficiency is the built-in provision for inspecting the inside of the engine without disassembling it.

How is this performed?

- (a) With borescope or with one of its modern counterparts.
- (b) Access ports to visually monitor the engine in service.
- (c) Annual inspection.

If choice a is selected set score to 1.

90. To clean the gas path, washing with pure water is to recover the...

- (a) gas path through the exhaust.
- (b) EGT margin.
- (c) low EPR output.

If choice b is selected set score to 1.

91. The procedures for preserving and depreserving gas turbine engines vary depending upon...

- (a) age of the engine, the type of preservative used.

- o (b) humidity local conditions.
- (c) the length of inactivity, the type of preservative used, and whether or not the engine may be rotated during the inactive period.

If choice c is selected set score to 1.

92. Engines which have been removed from aircraft to storage, or uninstalled engines which are being returned for repair or overhaul, should be protected internally and...

- o (a) wiped clean of foreign object material.
- (b) sealed in moisture vapor proof (MVP) envelopes.
- o (c) stored in a moisture free container.

If choice b is selected set score to 1.

If assessment score is 0% to 100% Feedback